

ASSEMBLY INSTRUCTIONS FOR

1901-KHB-King Headboard

1901-KFB-King Footboard

1901-Q/KSR-Queen/King side rails

Caution: Please read instructions thoroughly before unpacking assembly parts. Sharp, exposed staple tips can cause injury, therefore, for your protection, please remove any exposed staple used in packing.

1. We recommend that you assemble this product with the assistance of another person; this will make the assembly easier, and will help eliminate damage to the product or injury to persons during assembly.
2. Be sure to check all packing materials carefully for small parts that may have come loose inside the carton during shipment.
3. Please do not over tighten screws or bolts
4. Please put all parts on a non-abrasive floor before assembly, and follow the assembly steps to assemble your newly purchased product correctly and efficiently.

HARDWARE LIST OF HEADBOARD

NO.	SKETCH	COMPONENT	Q'TY
1		JCBC Bolt Ø5/16**1-1/2"	2pcs
2		JCBC Bolt Ø5/16**2"	6pcs
3		Spring Washer Ø5/16**12	8pcs
4		Flat Washer Ø5/16**19mm	8pcs
5		Allen Wrench 4mm	1pc

PART LISTS

NO.	DESCRIPTION	PICTURE	QTY
A	Headboard panel		1pc
B	Headboard leg (KD)		2pcs L=1 R=1
C	Headboard bottom rail		1pc

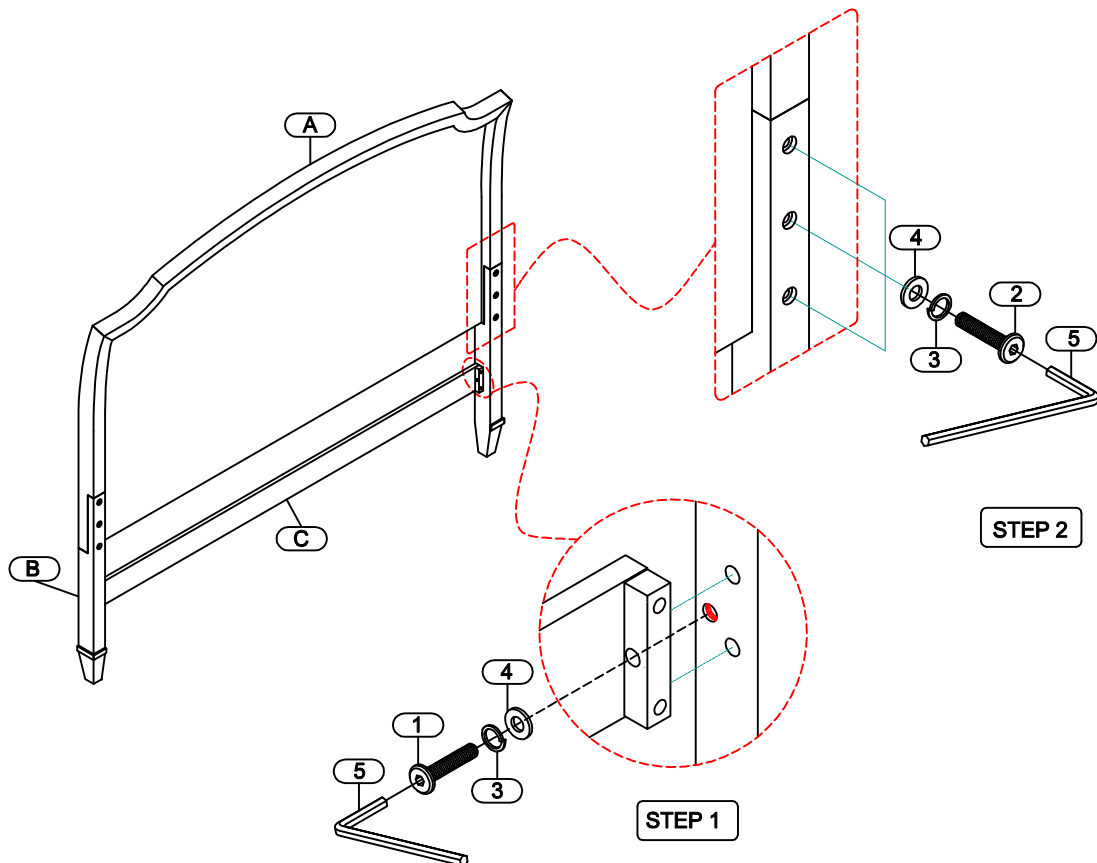

ASSEMBLY INSTRUCTIONS FOR

1901-KHB-King Headboard

1901-KFB-King Footboard

1901-Q/KSR-Queen/King side rails



HARDWARE LIST OF FOOTBOARD

NO.	SKETCH	COMPONENT	Q'TY
6		Ø8 x 30mm Wood Screw	10pcs

HARDWARE LIST OF SIDE RAILS

NO.	SKETCH	COMPONENT	Q'TY
7		Ø5/16" x 76mm Long Bolt	8pcs
8		37*17mm Arc Washer	8pcs
9		Ø5/16"-18 mm Nut	8pcs
10		12 mm Open Wrench	1pc

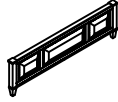
PART LISTS OF FOOTBOARD

NO.	DESCRIPTION	PICTURE	QTY
E	Footboard		1pc
F	Roll Slats		5pcs
G	Footboard Support Leg		10pcs

PART LISTS OF SIDE RAILS

NO.	DESCRIPTION	PICTURE	QTY
H	Rail		2pcs

STEP 3

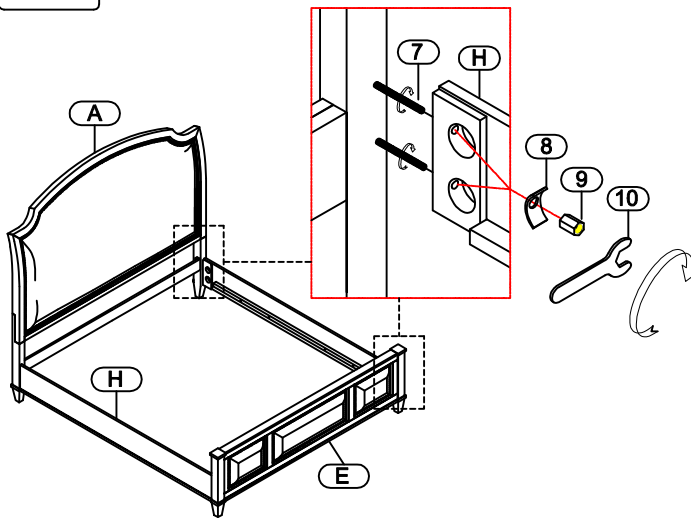

STEP 4

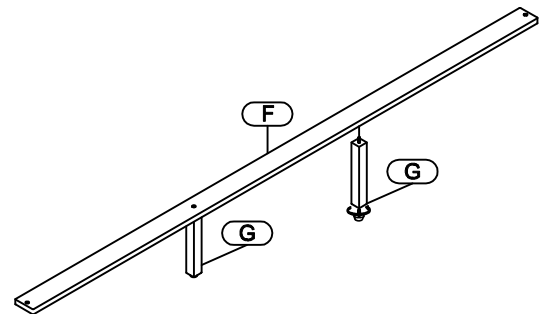

STEP 5

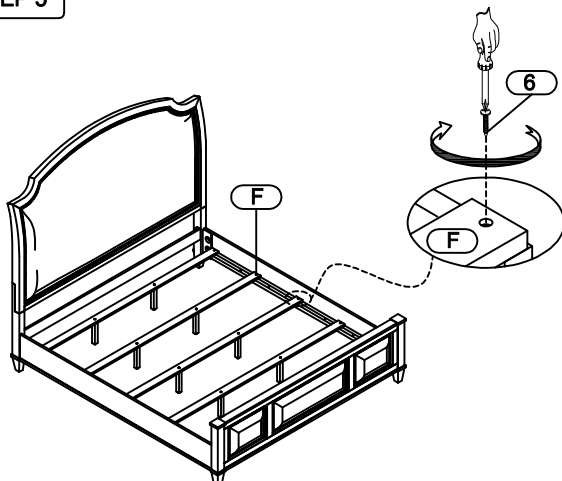

COMPLETE

