

POWER RECLINER WITH POWER HEADREST MODEL PANTHER

ASSEMBLY INSTRUCTIONS

IMPORTANT, RETAIN FOR FUTURE REFERENCE: READ CAREFULLY

Contents of Cartons

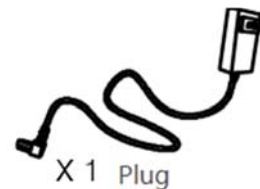
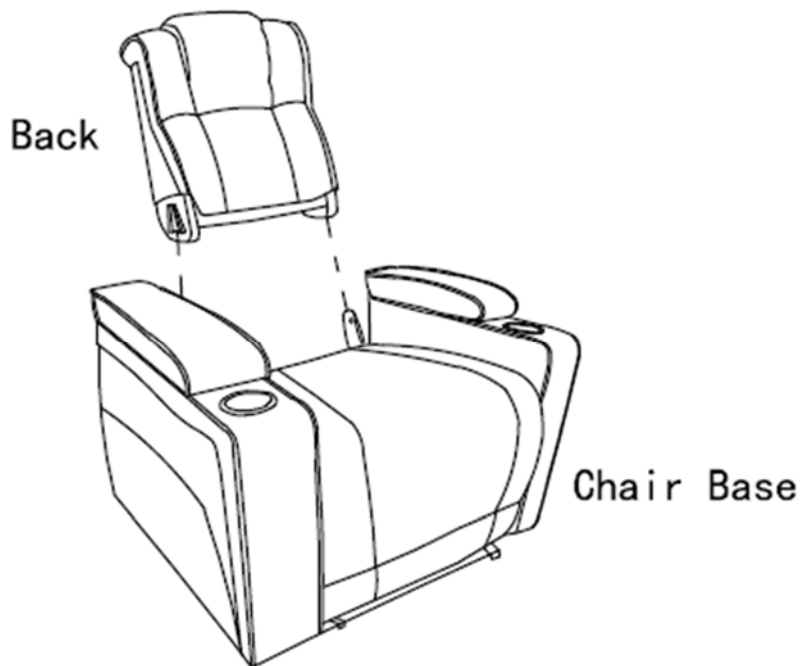

Assembly - Sofa

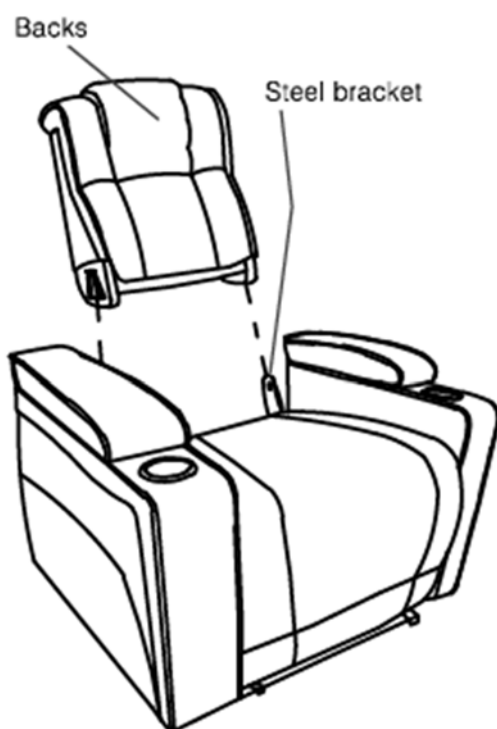

Step 1: Slide inside back receivers into the steel mechanism posts in the base of the furniture

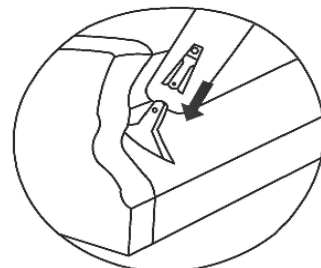

To remove the inside backs, use a screwdriver pressing outward on the black tab in the metal sleeve on both sides of the inside back and lift the inside back from the base of the Furniture

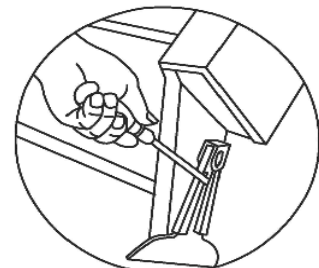

Electrical Connections

NOTE: The Power Transformer and Power Cord are located under the seats in separate boxes.

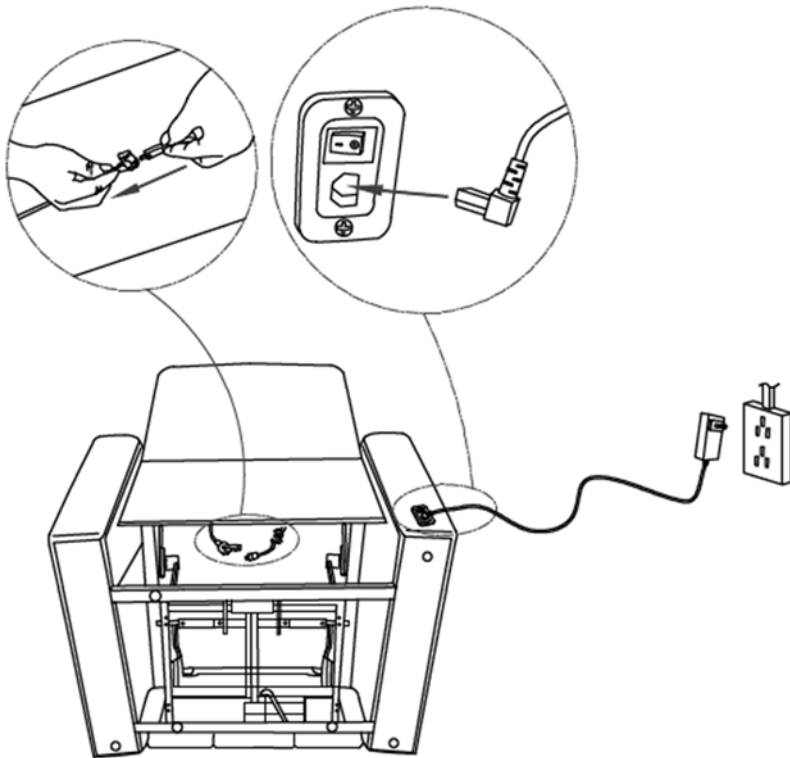

Power Transformer and Cord

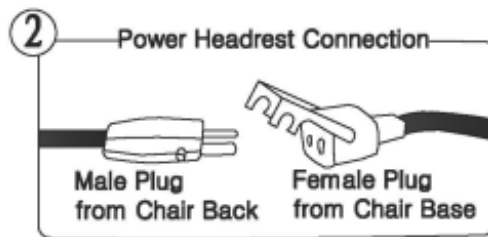
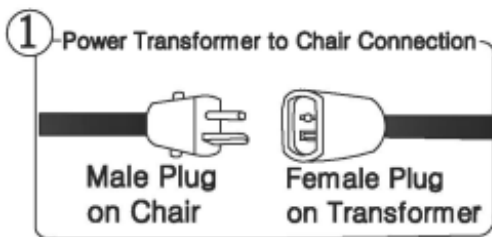

Electrical Controls

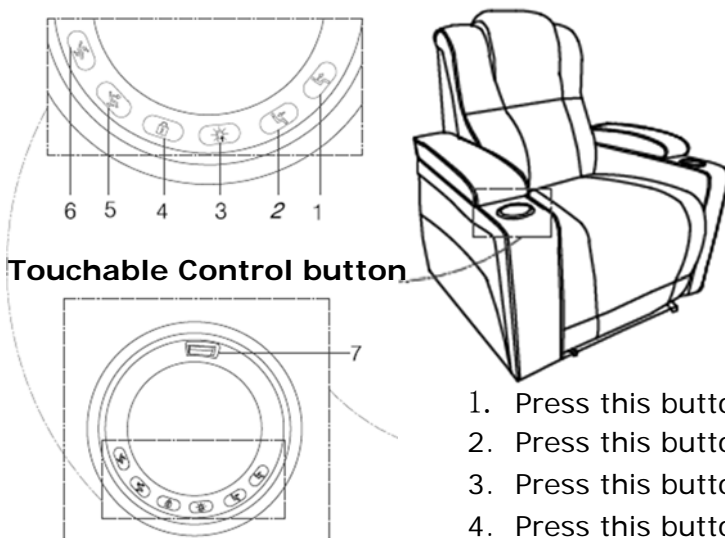

1. Press this button to raise the headrest up or forward
2. Press this button to lower the headrest back or down
3. Press this button to light up the cup & floor rails
4. Press this button for Children Lock
5. Press this button to raise the chair to the upright seated position
6. Press this button to recline the chair to your desired position
7. USB charger