

# ASSEMBLY INSTRUCTIONS

ITEM #: C8183A-GP0-XXXX&C8183A-GPG-XXXX&C8183A-BPN-XXXX  
KING PANEL BED

**Caution:** Please read instructions thoroughly before unpacking assembly parts. Sharp, exposed staple tips can cause injury, therefore, for your protection, please remove any exposed staple used in packing.

1. We recommend that you should assemble this product with the assistance of another person; this will make assembly easier, and will help to eliminate damage to the product or injury to persons during assembly.
2. Be sure to check all packing materials carefully for small parts that may have come loose inside the carton during shipment.
3. please do not over tighten screws or bolts until the assembly is complete.
4. Please put all parts on a non-abrasive floor before assembly, and follow the assembly steps to assemble your newly purchased product correctly and efficiently.

## TOOLS REQUIRED (NOT PROVIDED)

PHILLIPS SCREWDRIVER

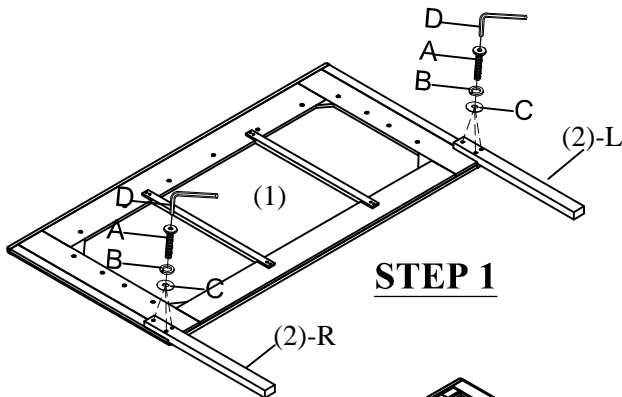

### STEP 1

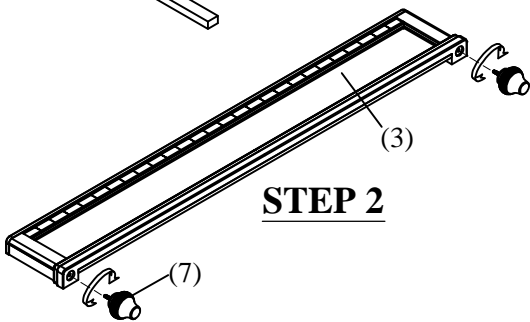

### STEP 2

## PART LISTS

NO.	Description	Sketch	Q'ty
(1)	UPHOLSTERY OF HEADBOARD		1PC
(2)	HEADBOARD LEG (L&R)		2PCS
(3)	FOOTBOARD PANEL		1PC
(4)	SIDE RAILS		2PCS
(5)	SLATS		4PCS
(6)	SUPPORT LEGS OF CENTER RAIL		8PCS
(7)	BUN FEET		2PCS

## HARDWARE LISTS

NO.	Description	Sketch	Size	Q'ty
A	BOLT		5/16"*45mm	6PCS
B	SPRING WASHER		5/16"	6PCS
C	FLAT WASHER		5/16"*19mm	6PCS
D	ALLEN KEY		4mm	1PC
E	SCREW M4*32		M4*32mm	8PCS

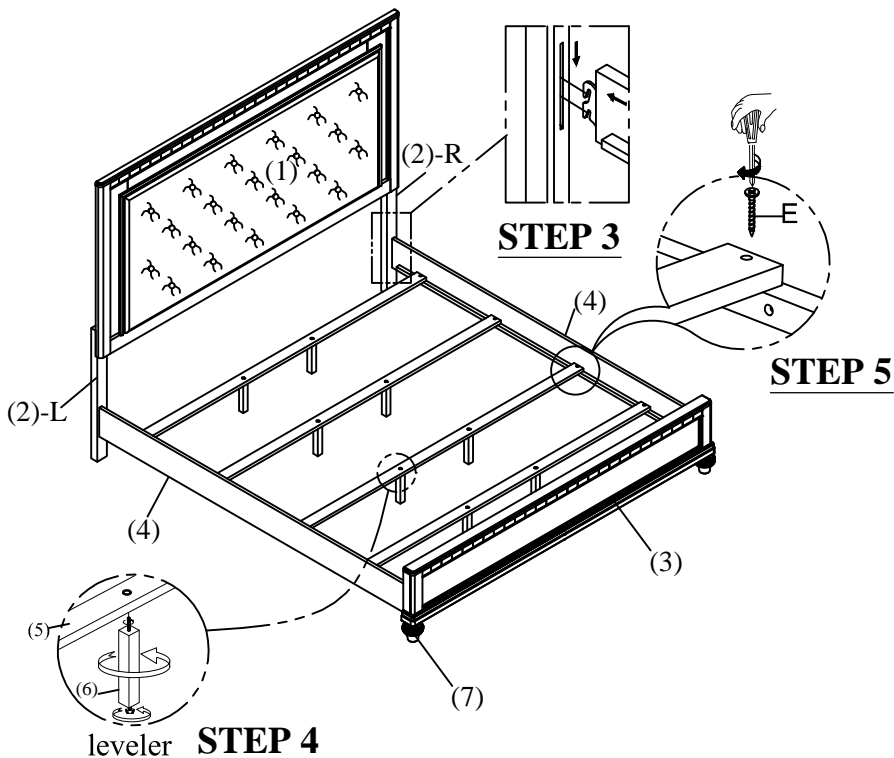

### STEP 3

### STEP 5

### STEP 4

leveler