



Item #	: HP900KHBW/D	HP900KFBW/D	HP900SRW/D
Description	: Highland Park King Size Upholstered Headboard	Highland Park King Size Upholstered Footboard	Highland Park King Size Uph. Side Rails
Product Size	: 83.5"x4.5"x72"	82.5"x3.5"x23"	82"x2.25"x8"

Your furniture purchase is an investment. Furniture can last life times, with a minimum amount of effort. Here are a few tips to properly care for your furniture, ensuring that it looks great year after year.

Wood Furniture Maintenance:

- Always dust, wipe, and clean with the grain of the wood.
- Dust with a soft cloth. Dust will scratch the furniture surface if not removed properly.
- Use the same type of polish consistently as interchanging oil-based and wax-based polishes will cause a build-up and result in a foggy or cloudy appearance.
- If a polished surface become foggy, rub it with a cloth dipped in a solution of one tablespoon vinegar to one quart of water .
- Rub softly with the grain until the surface is completely dry.
- Soap and water are not advisable for wood surfaces. Water can penetrate the finish and raise the grain on wood, causing damage.
- Remember to change dusting cloths frequently as dirty cloths may scratch your furniture's surface .
- The Enemies of Wood:
- Moisture is wood's worst enemy. Liquid spills should be gently wiped up immediately. Coasters should be used under all beverages.
- Do not allow rubber or vinyl materials to lie on the furniture. Chemicals in rubber may leave a stain.Put a strip of felt or leather under accessories that have rubber or vinyl.
- Heat creates a chemical change in the furniture's finish, which results in a white spot. Use protective pads under hot dishes, appliances, etc.
- Sunlight's ultraviolet rays can damage the finish of furniture. Do not place furniture directly against heater or radiator and do not place in the path of hot streams of air from central heating This will cause extreme localized drying of the wood.

High Gloss Resin Table Maintenance:

- Resin tabletops have approximately 1/8" of a resin coat on the top face of the table, which will resist ice, water, wine, liquor, food, cleaning fluids, and warm or hot liquids; however, cups, glasses, etc, containing hot liquids should not be left on the table without a coaster for protection.
- Resin tabletops will scratch just the same as any other glossy surface and basic precautions should be taken.
- For lasting shine, the resin should be waxed with a car wax the does not contain silicon. Maintaining this wax build-up will result in a high gloss shine.
- When wiping down the table, a soft, clean rag should be used. Do not use a heavy paper.

Granite Top Maintenance:

- The surface of granite on your table has been polished or sealed to create a generally non-porous surface. The stone has many natural characteristics including: veining, hairline cracks, and color variations- which make up the stone's beauty.
- To maintain the beauty of your granite:
- Protect surfaces from scratching, staining and etching by
 - *Keeping them free of debris or sharp objects.
 - *Wiping up spills immediately.
 - *Avoiding contact with chemicals (particularly acid -based materials)
 - Clean with pH neutral products or those especially formulated for use on stone.
 - It is not recommended to use a water - based solvent for dark granite as it remove the polish from the surface.
 - After a period of use, apply a penetrating sealer to prevent contaminants from being absorbed into the stone.
 - Remove stains with special absorbent poultices formulated for use on stone.
 - Renew the surface on polished granite (granite with a high gloss surface) by buffing with special stone polish, powder or cream.
 - Do not use granite polish on granite with a matte finish, which has been honed rather than polished. (Penetrating sealer may be used on both polished and honed granite).

Marble Top Maintenance :

- Marble may be stone, but it is porous stone and can stain easily. Treating marble surfaces the same as wood surfaces is a great rule of thumb.
- It is recommended to seal the tops on a regular basis (every 6 to 12 months) A good quality stone sealer can be purchased from any tiles/stone store or any homecare store and should be applied according to the manufacture's recommendation.
 - When sealed properly, marble tops can be used indoors and outdoors and can withstand any weather conditions except internal freezing. Snow or freezing rain will penetrate the table and cause cracks.

Caring for the Fabric on Upholstered Furniture:

- Frequent vacuuming of the entire upholstered area will prevent dust from settling in to the fibers.
- Professional cleaning is always recommended for all upholstered pieces.
- Always pre -test a small area of fabric in a inconspicuous area when cleaning before proceeding.
- Do not use cleaning products containing brightening agents.

VERY IMPORTANT !!

<p>NEVER USE GLASS CLEANERS ON FINISHED SURFACE AMMONIA WILL CHEMICALLY ATTACK THE FINISH.</p>	<p>DO NOT WRITE DIRECTLY ON SURFACE </p> <p style="text-align: center; color: blue;">PREVENT MARKING</p>	<p>DO NOT PLACE DIRECTLY IN SUNLIGHT </p> <p style="text-align: center; color: blue;">PREVENT FADING</p>	<p>DO NOT WRITE PLACEMATS WITH RUBBER BASES </p> <p style="text-align: center; color: blue;">PREVENT DISCOLORING</p>
<p>NEVER ALLOW LIQUIDS OF ANY KIND TO LINGER ON SURFACE ABSORPTION CAUSES THE WOOD TO WARP AND THE FINISH TO DE-LAMINATE</p>	<p>DO NOT USE COMMERCIAL POLISHES AND WAXES </p> <p style="text-align: center; color: blue;">PREVENT YELLOWING</p>	<p>DO NOT PLACE HOT POTS, ETC ON SURFACE </p> <p style="text-align: center; color: blue;">PREVENT DAMAGE TO FINISH</p>	<p>DO NOT USE COMMERCIAL POLISHES AND WAXES </p> <p style="text-align: center; color: blue;">PREVENT SPLITTING</p>

ASSEMBLY INSTRUCTIONS

HP900KHBW/D HP900KFBW/D HP900SRW/D

STEP 1

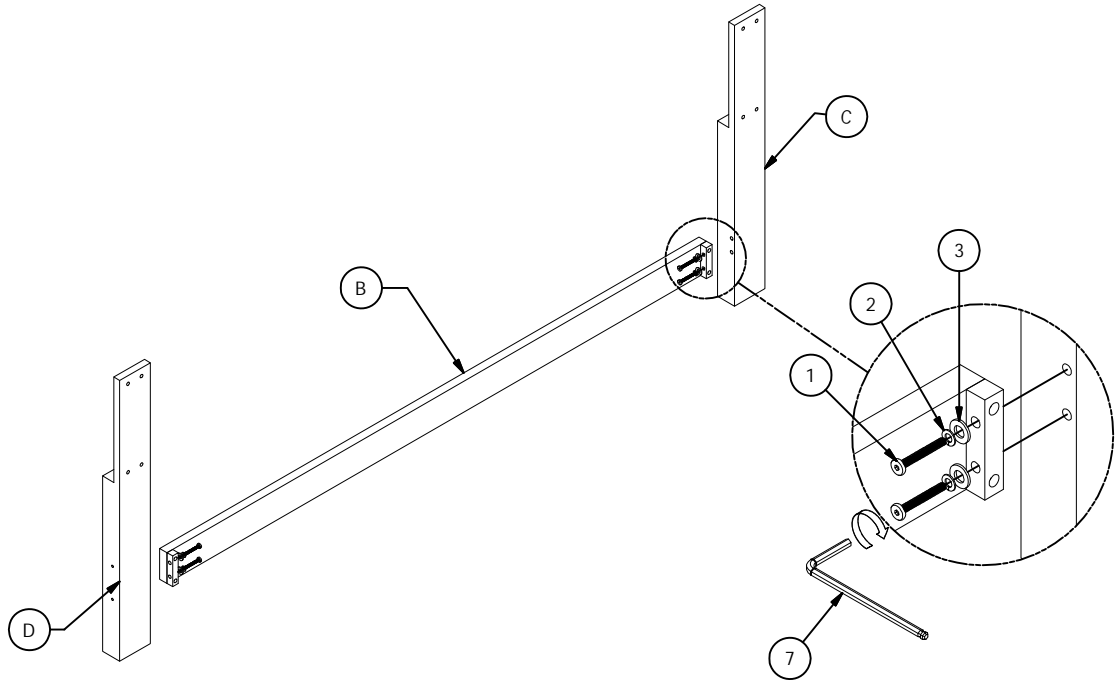

Step 1: Place all parts down on a piece of cloth or carpet to prevent finish from scratching. insert allen bolt (1), lock washer (2), flat washer (3) into the hole to the bottom support (B) and then assemble with leg (C) & (D). tighten with allen key (7)

STEP 2

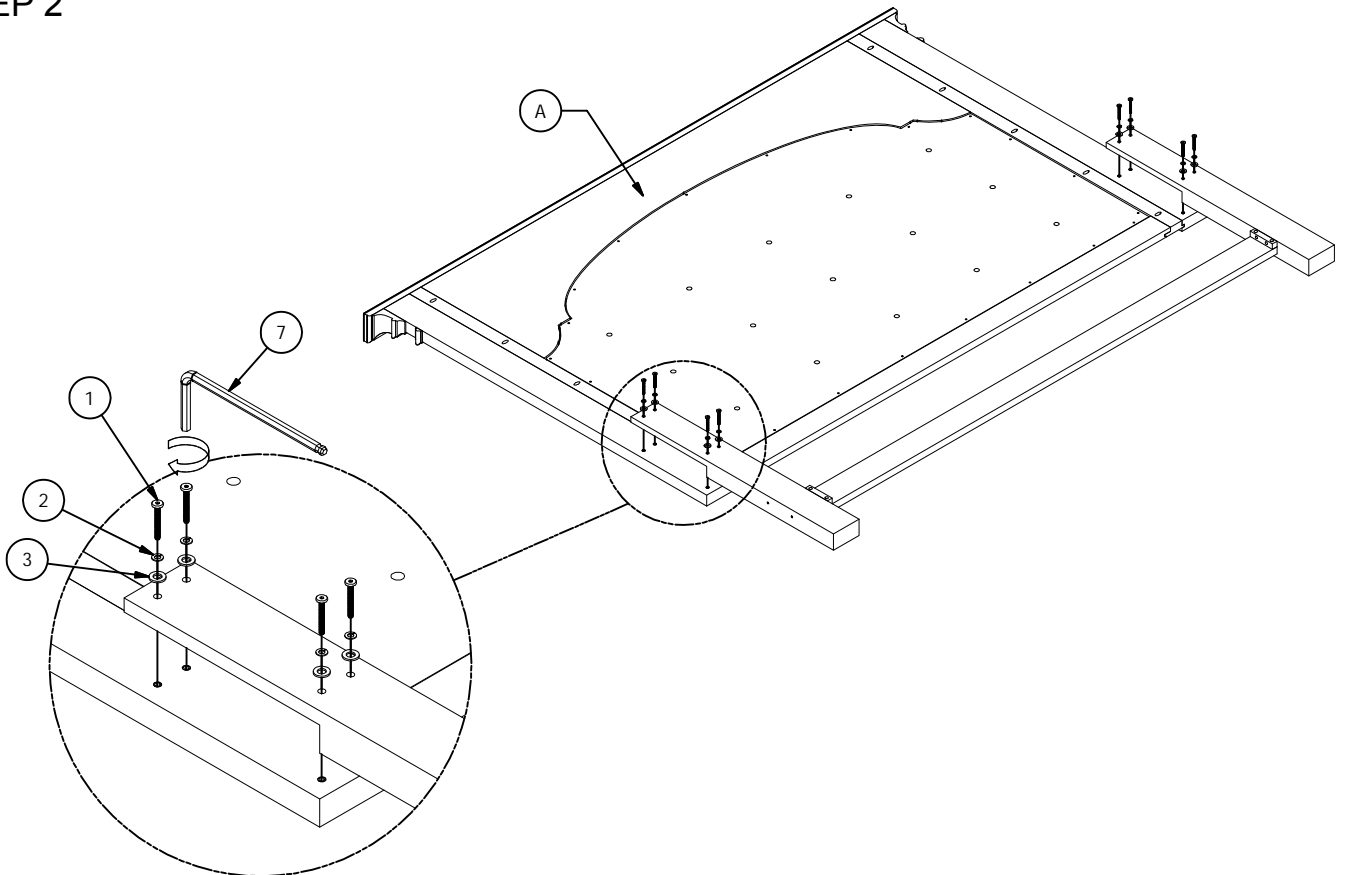

Step 2: Attach assembly bottom support with leg into the panel headboard(A). insert the allen bolt (1), lock washer (2), flat washer (3) into the hole, tighten with allen key(7)

ASSEMBLY INSTRUCTIONS

HP900KHBW/D HP900KFBW/D HP900SRW/D

STEP 3

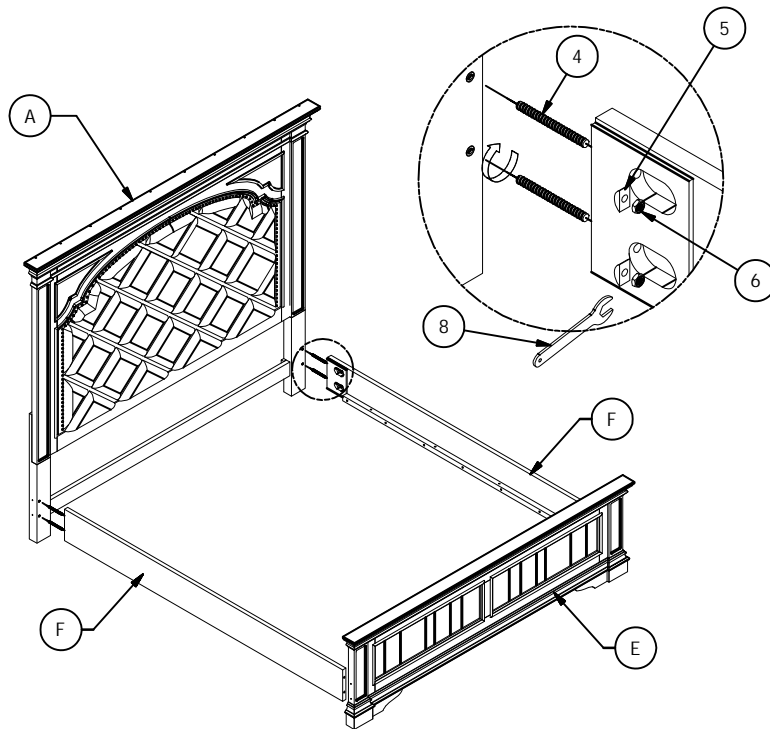

Step 3: Insert the long drat (4) into the assembly headboard (A) and footboard (E), tighten all long drat at this time. Then assemble side rail to headboard and footboard using halfmoon (5), hex nut (6) as picture shown, tighten with wrench(8)

STEP 4

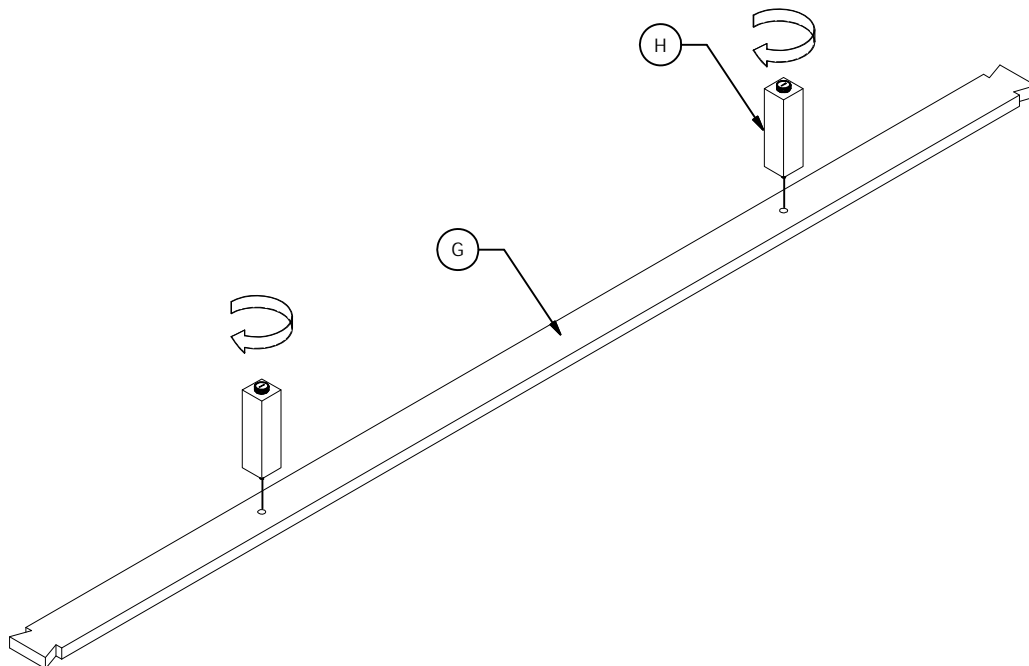

Step 4: Assemble the middle leg (H) with slat (G). tighten at this time.

ASSEMBLY INSTRUCTIONS

HP900KHBW/D HP900KFBW/D HP900SRW/D

STEP 5

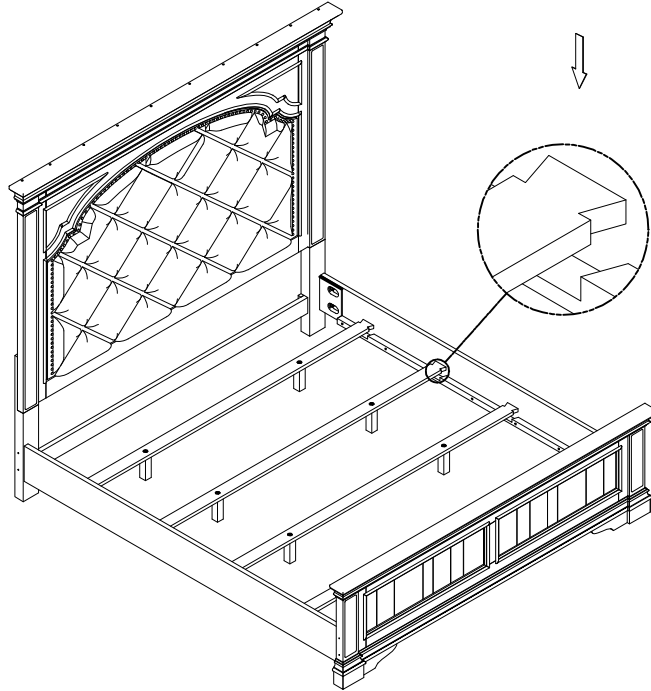



Step 5: Attach the assembly slat with middle leg into the groove on the side rail. assembly product is now completed.

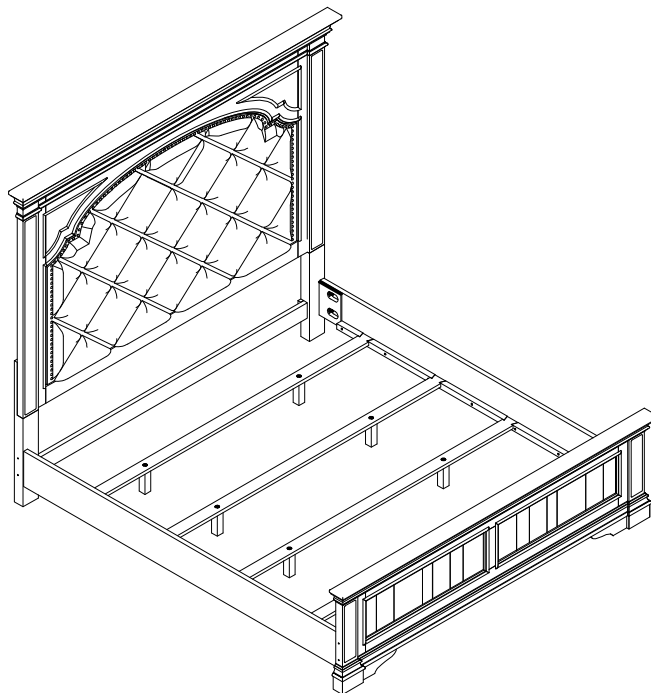



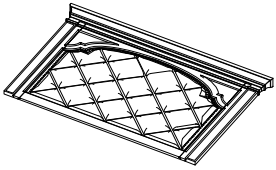
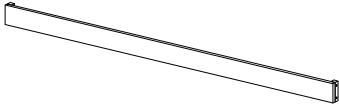
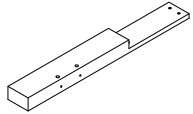
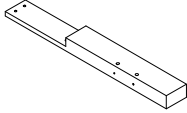
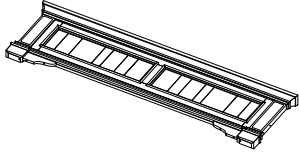
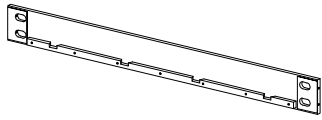

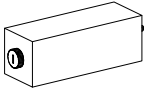

STEP 6

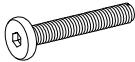

PARTS LIST

(A) HEADBOARD (1PC)	(B) BOTTOM SUPPORT (1PC)	(C) LEFT LEG (1PC)
		
(D) RIGHT LEG (1PC)	(E) FOOTBOARD (1PC)	(F) SIDE RAILS (2PCS)
		
(G) SLAT (4PCS)	(H) MIDDLE LEG (8PCS)	
		

HARDWARE PACK

NO.	DESCRIPTION	DIMENSION	Q' TY
1	ALLEN BOLT	 Ø1/4"x1-3/4"	12PCS
2	LOCK WASHER	 Ø1/4"x10	12PCS
3	FLAT WASHER	 Ø1/4"x13	12PCS
4	LONG DRAT	 Ø5/16"x4"	8PCS
5	HALFMOON	 Ø5/16"x27X14X6	8PCS
6	HEX NUT	 Ø5/16"	8PCS
7	ALLEN KEY	 Ø4x85	1PC
8	WRENCH	 Ø5/16"x4"	1PC

PARTS FOR HP900KHBW/D HP900KFBW/D HP900SRW/D COMPLETE HARDWARE PACK PHP900H

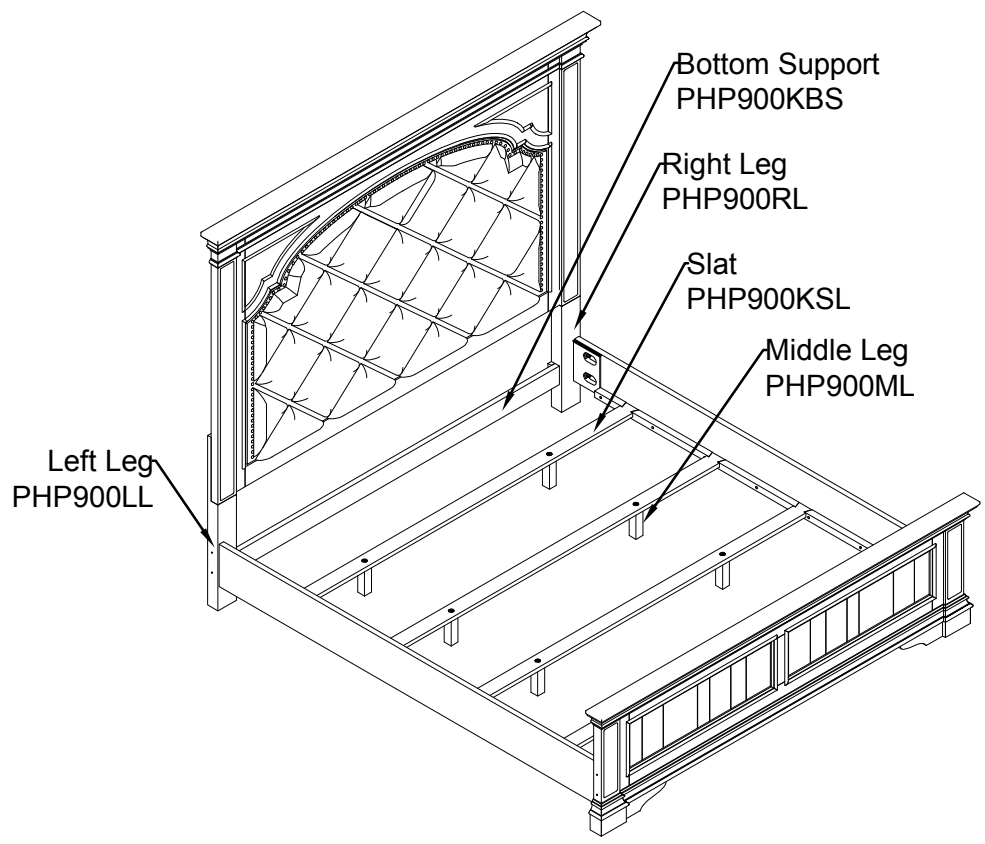

PRODUCT DETAILS

HEADBOARD		FOOTBOARD	
Panel	Mdf Mindi Veneer	Panel	Mdf Mindi Veneer
Frame	Acacia Wood	Frame	Acacia Wood
Upholstery	100% Polyester	Product Size	82.5"Lx3.5"Wx23"H
Product Size	Foam Normal D22	Carton Size	86.4"x27"x6.7"
Carton Size	83.5"Lx4.5"Wx72"H	Net Weight	63.93Lbs
Net Weight	87.6"x60"x7.1"	Gross Weight	79.36Lbs
Gross Weight	116.84Lbs	Cuft	9.4'
Cuft	132.27Lbs		
	21.7'		
SIDE RAILS			
Panel	Plywood		
Frame	Kruing Wood		
Product Size	82"Lx2.25"Wx8"H		
Carton Size	85.8"x11.8"x6.9"		
Net Weight	22Lbs		
Gross Weight	30.9Lbs		
Cuft	4.4'	MADE IN INDONESIA	