

Read this instruction carefully. See hardware and furniture part list for guidance. Be sure all part is complete, before you assemble. Place all wooden furniture part on a clean and flat soft surface to prevent from being scratched. Follow the figure to start assembling.

CAUTIONS :

1. Do not FULLY-TIGHTEN the nut or nut bolt until all nut or bolt is ready assembled.
2. Do not OVER-TIGHTEN the nut or nut bolt to avoid causing damages to the thread.
3. Keep all hardware part out of reach of children.

PART LIST			HARDWARE LIST		
ITEM	DESCRIPTION	QTY	ITEM	DESCRIPTION	QTY
A	CHAIR BACK	1 PC	1	JCBC SCREW M6 x 35MM	2 PCS
B	FRONT LEG L & R	2 PCS	2	JCBC SCREW M6 x 60MM	4 PCS
C	SEAT FRAME	1 PC	3	JCBC SCREW M6 x 80MM	4 PCS
D	SIDE STRETCHER	2 PCS	4	SPRING WASHER 1/4"	10 PCS
E	CUSHION SEAT	1 PC	5	FLAT WASHER 1/4"	10 PCS
			6	ALLEN KEY M4 (BALL SHAPE)	1 PC
			7	PAN HEAD SCREW # 8 x 32MM	7 PCS

STEP 1 :

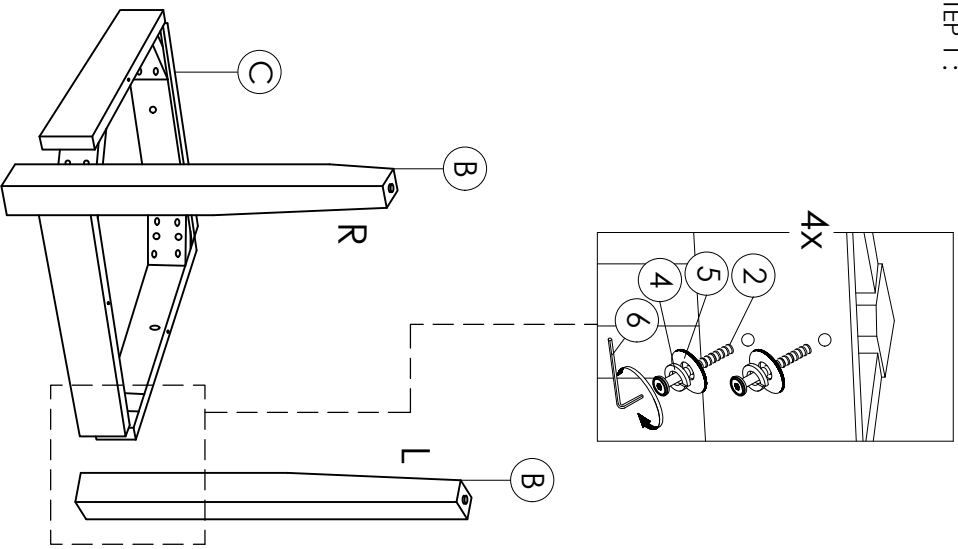

STEP 2 :

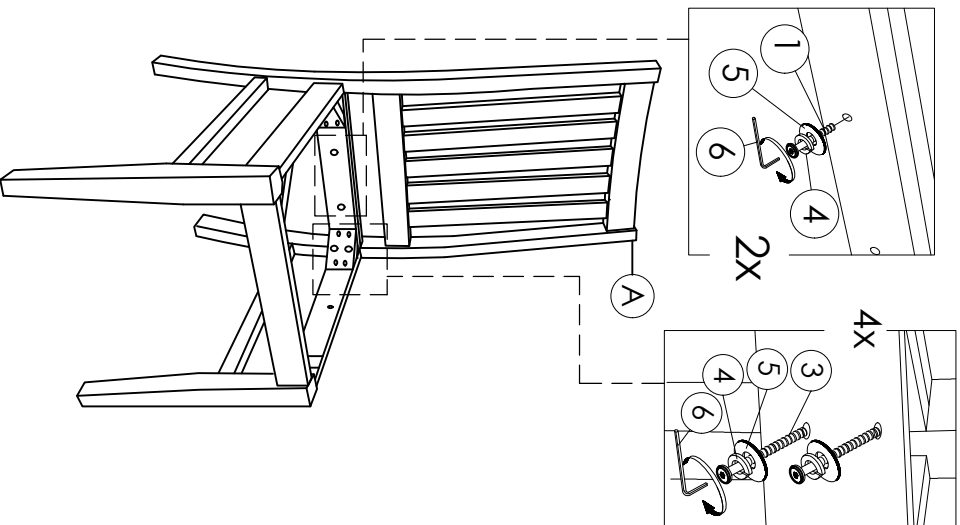

STEP 3 :

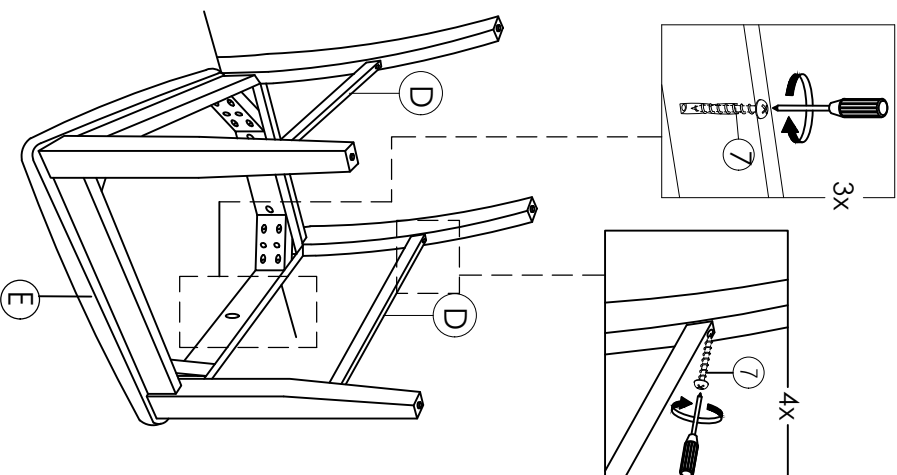

COMPLETED

